

# YACHT-TRANSPORTER

YT-10/YT-20/YT-30/YT-40



• YT-10/YT-20/YT-30/YT-40

## YACHT-TRANSPORTER

### Features

- Designed and build with simplicity of use and service in mind
- Guaranteed parallel movement of the four lift cylinders
- Standard remote control
- Independent 2x2 wheel steering creating outstanding manoeuvrability

### Advantages

- Tailor made solutions (size wise)
- Low manpower costs, easily operated by one person
- Very easy to operate with forklift or tractor
- For all types of terrain by the use of ebonite or pneumatic wheels and bogie construction

### Benefits

- 30% longer working life
- 70% less maintenance cost

**VERMEER MARINE**  
— LIFT & CARRY —



Aengwinderweg 57 | 8449 BA Terband-Heerenveen | The Netherlands  
t +31 513 67 17 68 | f +31 513 67 16 25 | e info@vermeermarine.com | www.vermeermarine.com

# YACHT-TRANSPORTER

YT-10/YT-20/YT-30/YT-40



## YT-10/YT-20/YT-30/YT-40

Vermeer Marine offers a range of boat handling equipment like Yacht-Cranes, Transporters and Frames.

The Vermeer Marine Yacht-Transporters are available in four types, the YT-10, YT-20, YT-30 and YT-40 with a lifting and transport capacity of 10, 20, 30 or 40 tons. The Yacht-Transporter is deliverable with ebonite or pneumatic wheels with bogie construction for all kinds of terrain.

The primary qualities of the Yacht-Transporter are its robust, compact and low profile construction, the low level of maintenance required, the guaranteed parallel movement of the four lift-cylinders and the outstanding manoeuvrability. This manoeuvrability ensures that boats can be parked as close to each other as is physically possible making the very best of the expensive storage space. The Yacht-Transporter is towed by a light forklift or tractor, which also provides the required oil pressure and volume for the steering and lift functions. Control of both steering and lift functions is via remote control.

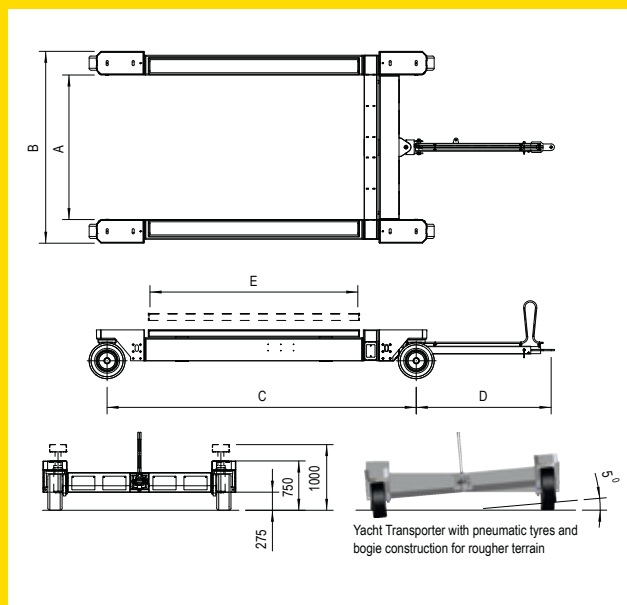

### Technical information

Power	
Hydraulic power source	forklift or tractor hydraulics
Required pump capacity	approx.20-30 l
Required working pressure	200 bar
Required electrical feed	12 V
Hydraulic functions	
Valves general	electrical over hydraulic
Valves lift/lower	on/off
Valves steering	on/off
Lifting height	20 up to 25 cm.
Capacity	
YT-10	max.10 tons
YT-20	max.20 tons
YT-30	max.30 tons
YT-40	max.40 tons
Controls	
Radio remote control	- wheel steering front - wheel steering rear - lift/lower control
Wire length	customer specification
Dimensions machine	
Length	3800 up to max.5000 mm*
Width	2200 up to max.3200 mm*
Height	750-900
Length pul	customer specification

\*on customers request.

## WE'LL CARRY ON

**VERMEER MARINE**  
— LIFT & CARRY —



Aengwilderweg 57 | 8449 BA Terband-Heerenveen | The Netherlands  
t +31 513 67 17 68 | f +31 513 67 16 25 | e info@vermeermarine.com | www.vermeermarine.com